

# RAiO

# RA6963

图形/文字

**LCD 控制器**

**基本规格书**

Version 1.4

July 07, 2009

RAiO Technology Inc.

©Copyright RAiO Technology Inc. 2007, 2008, 2009

## 1. 简介

RA6963 是一个文字与绘图模式的点矩阵液晶显示(LCD) 控制器，它可以支持大部份的液晶驱动器，用于各式标准化与客制化 LCD 模块。内建 256-word 的 ROM 字形产生器，可以显示基本英文字型、数字符号等字母，并支持最大 64KByte 的外部显示内存(Display RAM)，可用于文字显示模式、绘图显示模式及两总混合显示模式，显示窗口也可以轻易的在显示内存范围内移动。在 MCU 接口方面，RA6963 支持 8080 系列之 MCU，提供 8-Bit 的数据总线接口，功能上与 T6963C 完全兼容。

## 2. 特性

- 支持显示范围：
    - 行 → 32, 40, 64, 80
    - 列 → 2, 4, 6, 8, 10, 12, 14, 16, 20, 24, 28, 32
  - 支持 8080 8-bit MCU 接口
  - 内建 256-word 字型 ROM: 基本英文、日文、数字符号
  - 最大可支持 64Kbyte 外部显示内存(Static SRAM)
  - 显示模式: 支持文字、绘图与两种混和显示模式
  - 字型规格：
- 水平 → 5, 6, 7, 8 Pixel
  - 垂直 → 8 Pixel
  - 支持粗体文字显示与全屏幕反白
  - 支持大部份的液晶驱动器
  - 支援 1/16 ~1/128 Duty
  - 内建石英振荡器或外部时脉输入
  - 电源操作范围: 3.0~5.5V
  - 包装: LQFP-67Pin (RoHs 制程)

## 3. 接脚图

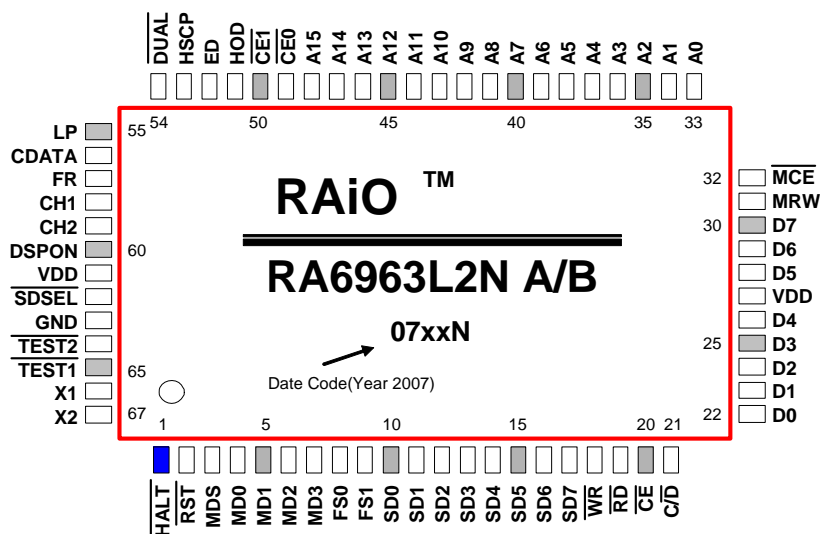

RA6963L2NA : LQFP-67 Pin, 无铅制程封装, Font-01 (参考完整规格书第 6-20 节)

RA6963L2NB : LQFP-67 Pin, 无铅制程封装, Font-02

## 4. 系统方块图

RA6963 内部主要是由 256-word 的字形产生器(Character Generator)、缓存器(Command Registers)、LCD 控制器及微控制器接口(MCU I/F)及等所组成。

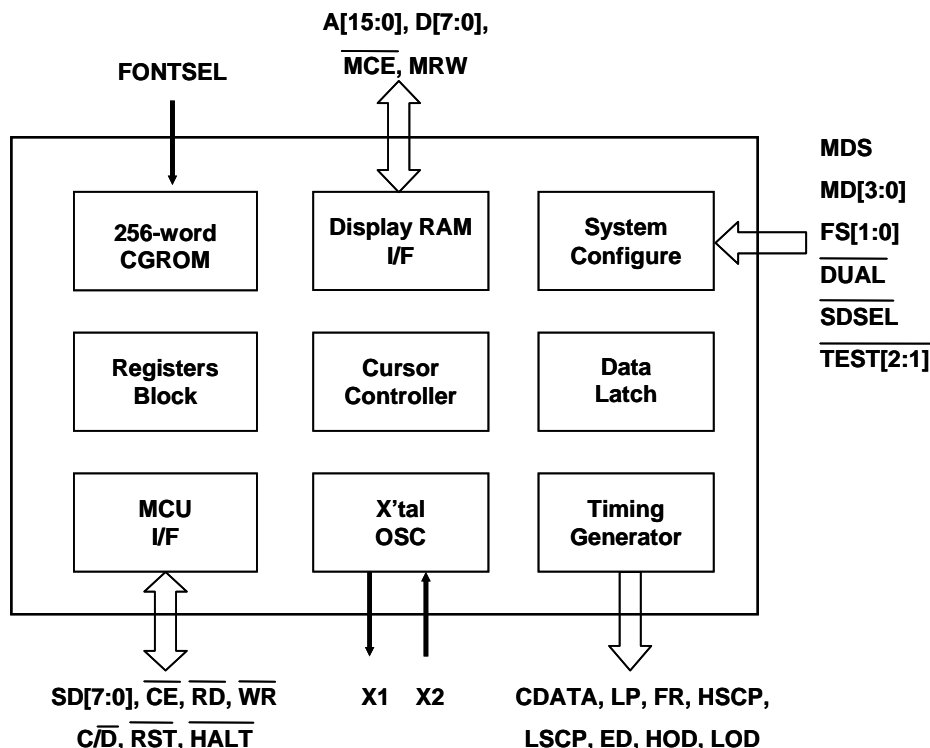

## 5. 脚位定义

### 4.1 MCU 界面

Pin Name	I/O	Description
SD[7..0]	I/O	<b>数据总线(Data Bus)</b> 负责在 RA6963 及微处理器(MCU)之间做数据传送与接收。
$\overline{RD}$	I	<b>控制讯号(Read Control or Enable)</b> $\overline{RD}$ 为数据读取讯号, 在低电位动作。
$\overline{WR}$	I	<b>控制讯号(Write Control or Read-Write Control)</b> 此脚位为数据写入讯号( $\overline{WR}$ ), 于低电位动作。
C/ $\overline{D}$	I	<b>控制讯号(Command/Data Select or Register Select)</b> 此脚位为 Data 与 Command 的选择信号, C/ $\overline{D}$ 为 1 时表示缓存器存取周期(Command Cycle), 为 0 表示数据存取周期(Data Cycle)。

$\overline{CS}$	I	<p><b>芯片选取(Chip Select)</b></p> <p>当 <math>\overline{CS}</math> 是 Low 时, RA6963 会处于致能, 可接受指令, 反之, 则不可接受指令。</p>
-----------------	---	--

#### 4.2 LCD Driver 界面

Pin Name	I/O	Description
FR	O	<b>Frame</b>
LP	O	<b>Latch</b> 给 LCD 行驱动(Column Driver)的锁定脉波。
CDATA	O	<b>同步数据(Synchronous Data)</b> 给 LCD 列驱动(ROw Driver)的同步数据。
HSCP	O	<b>移位脉波(Shift Clock Pulse)</b> 给 LCD 上半部行驱动(Column Driver)的移位脉波。
HOD	O	<b>数据输出(Data Output)</b> LCD 上半部的奇数行数据输出。
ED	O	<b>数据输出(Data Output)</b> $\overline{SDSEL} = 1 \rightarrow$ LCD 上半部与下半部的偶数行数据输出。 $\overline{SDSEL} = 0 \rightarrow$ LCD 上半部与下半部的行(Column)数据输出。
DSPON	O	<b>LCD 显示开启讯号 (Display On)</b> 控制 LCD 显示的开启讯号。当 $\overline{HALT}$ 或 $\overline{RST}$ 为 0, DSPON 输出为 0(LCD 显示关闭)。

#### 4.3 Memory 界面

Pin Name	I/O	Description
A[15:0]	O	<b>内存地址线(Address Output for External Memory)</b>
D[7:0]	I/O	<b>内存数据线(Data Bus for External Memory)</b>
$\overline{MCE}$	O	<b>内存芯片选择(Memory Chip Enable)</b> $\overline{MCE} = 0 \rightarrow$ 内存致能(Enable)。 $\overline{MCE} = 1 \rightarrow$ 内存禁能(Disable)。
MRW	O	<b>内存读写控制(Memory Read/Write Control)</b> $MRW = 0 \rightarrow$ 内存写入(Write Enable)。 $MRW = 1 \rightarrow$ 内存读取(Read Enable)。

$\overline{\text{CE0}}$ LOD	O	内存芯片选择 0(Memory Chip Enable 0) If $\overline{\text{DUAL}} = 1 \rightarrow$ 地址线区域 0000~07FFh 的芯片选择。 If $\overline{\text{DUAL}} = 0 \rightarrow$ LCD 下半部的奇数行数据输出。
$\overline{\text{CE1}}$ LSCP	O	内存芯片选择 1(Memory Chip Enable 1) If $\overline{\text{DUAL}} = 1 \rightarrow$ 地址线区域 0800~0FFFh 的芯片选择。 If $\overline{\text{DUAL}} = 0 \rightarrow$ 给 LCD 下半部行驱动(Column Driver)的移位脉波。
VDD	P	电源输入
GND	P	电源接地

#### 4.4 其它接口

Pin Name	I/O	Description																																																																																																												
$\overline{\text{DUAL}}$	I	扫描选择(Scan Select) $\overline{\text{DUAL}} = 0 \rightarrow$ 双扫描(Dual-Scan)。 $\overline{\text{DUAL}} = 1 \rightarrow$ 单一扫描(Signal-Scan)。																																																																																																												
MDS MD[1:0]	I	<p><b>LCD 尺寸选择(LCD Size Selection)</b></p> <p>单一屏幕(One Screen):</p> <table border="1"> <tr><td><math>\overline{\text{DUAL}}</math></td><td>H</td><td>H</td><td>H</td><td>H</td><td>H</td><td>H</td><td>H</td><td>H</td></tr> <tr><td>MDS</td><td>L</td><td>L</td><td>L</td><td>L</td><td>H</td><td>H</td><td>H</td><td>H</td></tr> <tr><td>MD1</td><td>H</td><td>H</td><td>L</td><td>L</td><td>H</td><td>H</td><td>L</td><td>L</td></tr> <tr><td>MD0</td><td>H</td><td>L</td><td>H</td><td>L</td><td>H</td><td>L</td><td>H</td><td>L</td></tr> <tr><td>Lines</td><td>2</td><td>4</td><td>6</td><td>8</td><td>10</td><td>12</td><td>14</td><td>16</td></tr> <tr><td>V-Dots</td><td>16</td><td>32</td><td>48</td><td>64</td><td>80</td><td>96</td><td>112</td><td>128</td></tr> </table> <p>双屏幕(Two Screens):</p> <table border="1"> <tr><td><math>\overline{\text{DUAL}}</math></td><td>L</td><td>L</td><td>L</td><td>L</td><td>L</td><td>L</td><td>L</td><td>L</td></tr> <tr><td>MDS</td><td>L</td><td>L</td><td>L</td><td>L</td><td>H</td><td>H</td><td>H</td><td>H</td></tr> <tr><td>MD1</td><td>H</td><td>H</td><td>L</td><td>L</td><td>H</td><td>H</td><td>L</td><td>L</td></tr> <tr><td>MD0</td><td>H</td><td>L</td><td>H</td><td>L</td><td>H</td><td>L</td><td>H</td><td>L</td></tr> <tr><td>Lines</td><td>4</td><td>8</td><td>12</td><td>16</td><td>20</td><td>24</td><td>28</td><td>32</td></tr> <tr><td>V-Dots</td><td>32</td><td>64</td><td>96</td><td>128</td><td>160</td><td>192</td><td>224</td><td>256</td></tr> </table>	$\overline{\text{DUAL}}$	H	H	H	H	H	H	H	H	MDS	L	L	L	L	H	H	H	H	MD1	H	H	L	L	H	H	L	L	MD0	H	L	H	L	H	L	H	L	Lines	2	4	6	8	10	12	14	16	V-Dots	16	32	48	64	80	96	112	128	$\overline{\text{DUAL}}$	L	L	L	L	L	L	L	L	MDS	L	L	L	L	H	H	H	H	MD1	H	H	L	L	H	H	L	L	MD0	H	L	H	L	H	L	H	L	Lines	4	8	12	16	20	24	28	32	V-Dots	32	64	96	128	160	192	224	256
$\overline{\text{DUAL}}$	H	H	H	H	H	H	H	H																																																																																																						
MDS	L	L	L	L	H	H	H	H																																																																																																						
MD1	H	H	L	L	H	H	L	L																																																																																																						
MD0	H	L	H	L	H	L	H	L																																																																																																						
Lines	2	4	6	8	10	12	14	16																																																																																																						
V-Dots	16	32	48	64	80	96	112	128																																																																																																						
$\overline{\text{DUAL}}$	L	L	L	L	L	L	L	L																																																																																																						
MDS	L	L	L	L	H	H	H	H																																																																																																						
MD1	H	H	L	L	H	H	L	L																																																																																																						
MD0	H	L	H	L	H	L	H	L																																																																																																						
Lines	4	8	12	16	20	24	28	32																																																																																																						
V-Dots	32	64	96	128	160	192	224	256																																																																																																						
X1	I	石英振荡输入(Crystal Oscillator Input) 内建石英/陶瓷振荡电路及回授电阻, 外部电容则建议使用 15 到 20pF。如果使用外部 Clock 则由 X1 输入, X2 保持浮接。																																																																																																												
X2	O	石英振荡输出(Crystal Oscillator Output)																																																																																																												

FS[1:0]	I	<b>字型选择(Font Selection)</b> <table border="1"> <tr> <td><b>FS0</b></td> <td>H</td> <td>L</td> <td>H</td> <td>L</td> </tr> <tr> <td><b>FS1</b></td> <td>H</td> <td>H</td> <td>L</td> <td>L</td> </tr> <tr> <td><b>Font</b></td> <td>5 X 8</td> <td>6 X 8</td> <td>7 X 8</td> <td>8 X 8</td> </tr> </table>	<b>FS0</b>	H	L	H	L	<b>FS1</b>	H	H	L	L	<b>Font</b>	5 X 8	6 X 8	7 X 8	8 X 8
<b>FS0</b>	H	L	H	L													
<b>FS1</b>	H	H	L	L													
<b>Font</b>	5 X 8	6 X 8	7 X 8	8 X 8													
MD[3:2]	I	<b>行数选择(Columns Selection)</b> <table border="1"> <tr> <td><b>MD2</b></td> <td>H</td> <td>L</td> <td>H</td> <td>L</td> </tr> <tr> <td><b>MD3</b></td> <td>H</td> <td>H</td> <td>L</td> <td>L</td> </tr> <tr> <td><b>Columns</b></td> <td>30</td> <td>40</td> <td>64</td> <td>80</td> </tr> </table>	<b>MD2</b>	H	L	H	L	<b>MD3</b>	H	H	L	L	<b>Columns</b>	30	40	64	80
<b>MD2</b>	H	L	H	L													
<b>MD3</b>	H	H	L	L													
<b>Columns</b>	30	40	64	80													
$\overline{\text{SDSEL}}$	I	<b>数据选择</b> $\overline{\text{SDSEL}} = 0 \rightarrow$ 简易串行方式传送数据。 $\overline{\text{SDSEL}} = 1 \rightarrow$ 奇偶数分离方式传送数据。															
$\overline{\text{HALT}}$	I	<b>暂停信号(Halt)</b> $\overline{\text{HALT}} = 0 \rightarrow$ 停止振荡器 Clock。 $\overline{\text{HALT}} = 1 \rightarrow$ 正常状态。															
$\overline{\text{RST}}$	I	<b>外部重置信号(Reset)</b> $\overline{\text{RST}} = 0 \rightarrow$ RA6963 将被初始化。 $\overline{\text{RST}} = 1 \rightarrow$ 正常状态, RA6963 已内建 Pull-Hi 电阻。															
$\overline{\text{TEST}}[2:1]$	I	<b>测试接脚(Test Pins)</b> 此为测试专用脚位, 不需连接使用。															
CH1, CH2	O	<b>核对信号(Check Signals)</b>															
FONTSEL	I	<b>CGROM 字型选择</b> FONTSEL = 0 $\rightarrow$ 选择 CGROM Font 01. FONTSEL = 1 $\rightarrow$ 选择 CGROM Font 02.															

## 6. 系统应用

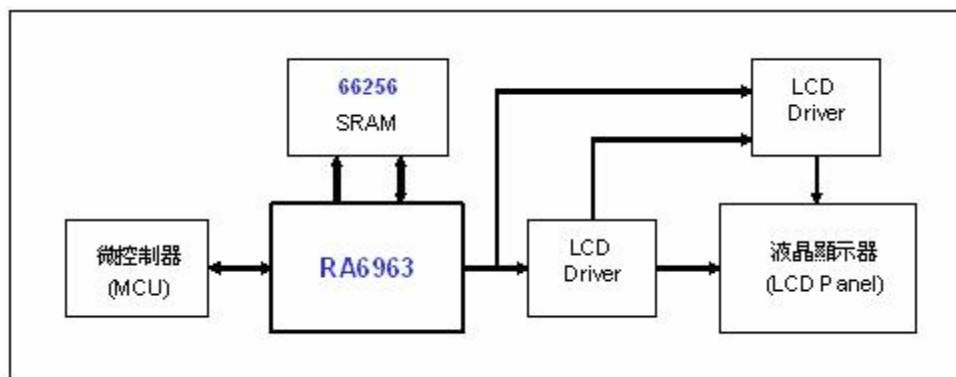

7. 应用电路

